

### Gemini Medium Wave Infrared E-Mitters

**Lead configurations and lengths** – 842°F (450°C), 600V insulated lead wire, 3/8" stripped ends standard, oriented straight out ends or at 90° to heater axis. Optional styles of high temperature insulated lead wire and un-insulated ring or spade terminals are available to suit your application. Select size and style from charts

on page 7-23. Bare stranded heater leads up to 9" long may be ordered with optional ceramic bead insulators. Longer lengths are available as lead wire options only. When ordering, specify lead orientation, style, length, and terminals.

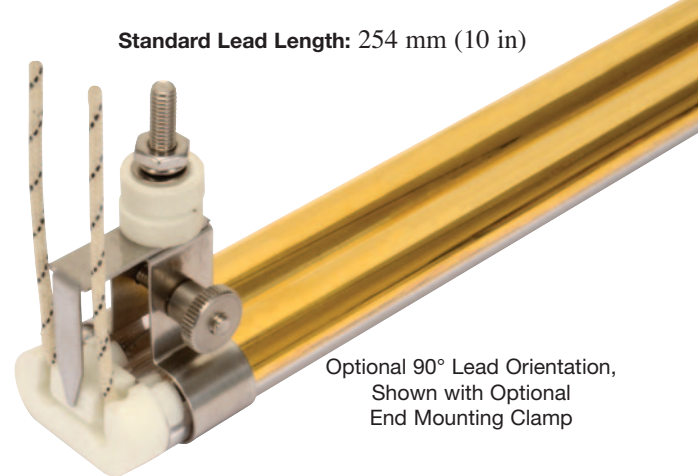
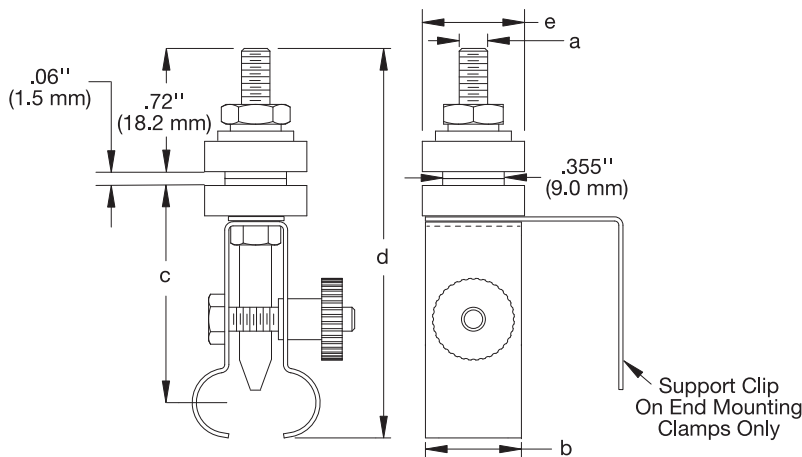

#### Gemini Stainless Steel Clamp Specifications and Dimensions

Clamp Assembly Part Number	CRK00085	CRK00086	CRK00087	CRK00088	CRK00089	CRK00090
<b>Fits Twin Tube Size</b>	18 × 8 mm		23 × 11 mm		33 × 15 mm	
<b>Clamp Location on Tube</b>	Center	End	Center	End	Center	End
<b>Clamps Required</b>	OAL > 39.4" (1000 mm)	2 per heater	OAL > 59.1" (1500 mm)	2 per heater	OAL > 78.7" (2000 mm)	2 per heater
<b>Mounting Stud Threads (a)</b>	10-32		10-32		10-32	
<b>Clamp Width (b)</b>	0.40" (10.2 mm)		0.40" (10.2 mm)		0.60" (15.2 mm)	
<b>Heater Mounting Height (c)</b>	1.20" (30.5 mm)		1.20" (30.5 mm)		1.41" (35.8 mm)	
<b>Overall Clamp Height (d)</b>	2.44" (62 mm)		2.48" (63.1 mm)		2.77" (70.3 mm)	
<b>Ceramic Insulator Diameter (e)</b>	0.59" (15 mm)		0.59" (15 mm)		0.59" (15 mm)	
<b>Panel Mounting Hole Diameter</b>	0.375" (9.5 mm)		0.375" (9.5 mm)		0.375" (9.5 mm)	

Recommended mounting panel thickness range is 18-14 ga.

#### Ordering Information

##### Stock Heaters

Order by Tempco Part Number for heaters listed on page 7-66.

##### Custom Engineered/Manufactured Heaters

Because TEMPCO understands that an electric heater can be very application specific, for sizes not listed TEMPCO will design and manufacture a Gemini Infrared Heater or modular housing to meet your requirements. **Standard lead time is 3 weeks.**

##### Please Specify the following:

- Reflective Coating — Gold, White Ceramic or None
- Twin Bore Tube Size (18 × 8 mm, 23 × 11 mm, or 33 × 15 mm)
- Wattage or Watts/In
- Single or Double End
- Overall Length (OAL)
- Heated Length (HL)
- Lead Orientation (0° or 90°)
- Voltage
- Quantity
- Lead Wire Terminals (page 7-23)
- Lead Wire Style/Length (Page 7-23)
- Winding Pattern (page 7-66, A-J or as required)
- Ceramic Bead Option (9" max. length)
- CRA Linear Housing Option (See page 7-68)
- Cold End Lengths (CE1 & CE2) See Winding Pattern page 7-66

**⚠ WARNING: Cancer and Reproductive Harm - [www.P65Warnings.ca.gov](http://www.P65Warnings.ca.gov).**

**(800) 323-6859 • Email: [sales@tempco.com](mailto:sales@tempco.com)**