

TEMPCO®

USER MANUAL

TEC-805

1/8 DIN Solid State Temperature Controller
Relay Output–Solid State Output–For Heating



The TEC-805 is designed to fit panel cutouts that are 1.781" (45mm) x 3.625" (92mm).
3" minimum depth is required to provide clearance for rear terminal connections.

Input

Thermocouple (T/C)	Type K, J. See Control label.
RTD	3-wire PT100 DIN or JIS
Cold junction compensation	Automatic
Input break protection	Built-in, upscale on open sensor and output off
Input impedance	10M ohm
Common mode rejection (CMR)	CMRR 120dB, min.
Normal mode rejection (NMR)	NMRR 60dB, min. (60Hz)

Control Output

Relay—heating	SPDT relay, 5 amps max resistive load at 120V, 240VAC, or 24VDC
Optional:	
20VDC	For output to solid state relay
4–20mA	For output to SCR
Relay—alarm	SPST relay, 2 amps max resistive load at 120V or 240VAC

Control Modes

On-Off	Differential 0.5% of full-scale range
Proportional	Proportional Band fixed at 2.5% of range. Proportional Cycle time 20 seconds for relay controls, 1 second for SSR controls

Indication

Output	Red LED lit, heater on/LED not lit, heater off.
--------	---

Set Point

Resolution	±1 Least significant digit
Accuracy	±1% of span
Repeatability	±1 significant digit
Manual Reset	Adjustable up to 2.6% of span

Power

Rating	90–264VAC, 50/60Hz. 24VAC/DC models can be special ordered.
Consumption	Less than 3VA.

Environmental and Physical

Operating Temperature	32–122°F (0–50°C)
Humidity	0–90% RH (non-condensing)
Insulation	20M ohm min. (500VDC)
Breakdown	2000VAC, 50/60Hz, 1 minute
Vibration	10–55Hz, amplitude 1.0mm
Shock	660ft/s ² (20g)
Weight	8oz. (227g)

Dimensions

Height:	3.75" (96mm) x Width: 1.875" (48mm) x Depth: 3.125" (80mm)
Depth behind panel:	2.559" (65mm)
Panel cutout	1.871" x 3.625" (46mm x 92mm)
DIN case	Plastic full plug-in construction with screw terminals on rear and adjustable brackets for panel mounting.

Mounting

When mounting one of these instruments, make sure the control and the ambient temperature remain within the 10–125°F range. The control may be mounted in any position. Once the control has been inserted into the panel, use the two mounting brackets provided with the unit to secure it. Use light to moderate pressure.

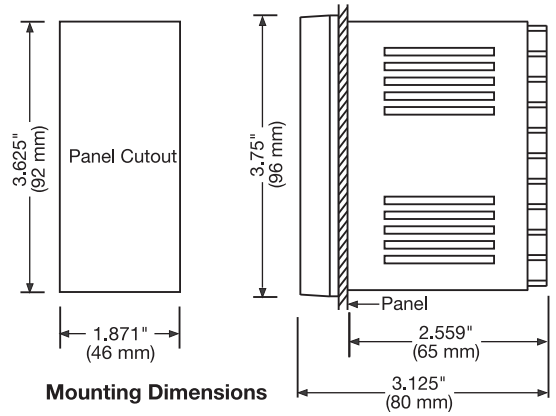

Manual Reset Adjustment

The reset adjustment is located on the front of the control. Approximately half an hour after adjusting the set point, when the process stabilizes, it may become necessary to adjust “reset” as well. Start with the reset adjustment pointing to zero. If the temperature indication stabilizes above the set point, adjust the reset to the “minus” side; if the temperature stabilizes below the set point, adjust to the “plus” side. Continue making adjustments until the temperature indication stabilizes at the set point. Make sure to allow 15 minutes between adjustments for stabilization.

Wiring

All wiring should conform to local and national codes.

When wiring the thermocouple, make sure that the thermocouple and extension wire conform to the thermocouple type specified by the instrument. The thermocouple and the extension wires must have the same polarity and be the same alloy. For accurate measurements, the total lead resistance should not exceed 100 ohms.

To assure effective lead resistance compensation when wiring three wire RTDs (Resistance Temperature Detectors), make sure that all of the leads that connect to the controller are the same gauge and composition. Connect the two common wires of the three wire RTD to terminals 17 and 18. When using a two wire RTD, install a jumper between terminals 17 and 18.

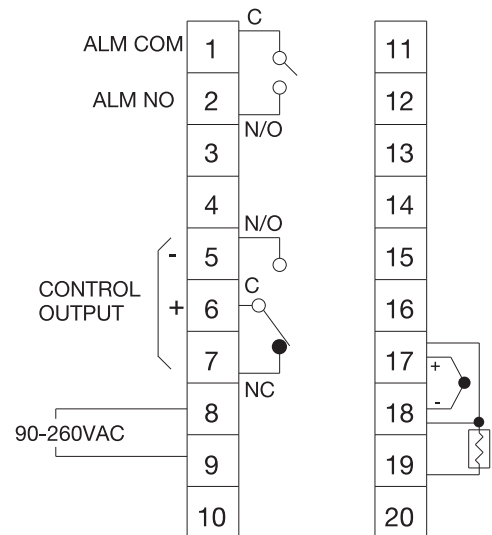

WARNINGS

1. Dangerous voltages may be present in these instruments. Before installation or troubleshooting, switch off and isolate power to all equipment. If a unit is suspected of being faulty, it should be disconnected and removed to a properly equipped workshop for testing and repair. Component replacement and internal adjustments should be performed by qualified maintenance personnel only.
2. To minimize the risk of fire or shock hazards, avoid exposing these instruments to rain or excessive moisture.
3. Do not use these instruments in areas that are prone to hazardous conditions such as excessive shock, vibration, dirt, moisture, corrosive gases, or oil. The ambient temperature of the areas should not exceed the maximum rating specified.

Wiring Precautions:

- Before wiring, verify the correct model number and options on the label. Switch off the power while checking.
- Care must be taken to ensure that the maximum voltage rating specified on the label is not exceeded.
- It is recommended that the power for these units be protected by fuses or circuit breakers rated at the minimum value possible.
- All units should be installed in a suitable enclosure to prevent live parts from being accessible to human hands and metal tools. Metal enclosures and/or subpanels should be grounded in accordance with national and local codes.
- All wiring must conform to appropriate standards of good practice and local codes and regulations. Wiring must be suitable for the voltage, current, and temperature rating of the system.
- Beware not to over-tighten the terminal screws. The torque should not exceed 1 N-m (8.9 lb-in or 10 KgF-cm).
- Unused control terminals should not be used as jumper points as they may be internally connected, causing damage to the unit.
- Verify that the ratings of the output devices and the inputs as specified are not exceeded.
- Except for thermocouple wiring, all wiring should use stranded copper conductor with a maximum gage of 14 AWG.
- Electrical power in industrial environments contains a certain amount of noise in the form of transient voltage and spikes. This electrical noise can adversely affect the operation of microprocessor-based controls. For this reason the use of shielded thermocouple extension wire which connects the sensor to the controller is strongly recommended. This wire is a twisted-pair construction with foil wrap and drain wire. The drain wire is to be attached to ground in the control panel only.

General Operation

Adjust the digital set point to the temperature desired. The “OUT” lamp will glow red, indicating that the control is calling for heat, and the relay is closed. As the process temperature approaches the set point, the control will begin to cycle the heaters on and off. When the heater load is turned off, the “OUT” lamp will not be lit. The actual process temperature measured by the sensor is indicated on the digital LED display.

Calibration Instructions

Calibration is performed using the four potentiometers located on the bottom of the left-hand circuit board. Open the control by unlatching the clamps on the top and bottom of the front of the control. Allow the control to warm up for at least half an hour before checking the calibration. The functions of the potentiometers is as follows:

- VR1 Low scale calibration
- VR2 Low scale switching point
- VR3 High scale switching point
- VR4 High scale calibration

You must set the “reset” adjustment to zero before calibration. VR1 and VR4 affect each other, so you should calibrate low scale and high scale at least three times each.

Alarm Operation (Optional)

The TEC-805 has the option of coming equipped with a form-A relay that can be used as a deviation alarm. It is called a deviation alarm because the alarm set point maintains the same deviation from the control set point, so if the control set point is changed, the alarm set point will change with it. The relay is rated for a maximum load of 2 amps, 240 volts. On units that have been ordered with the alarm option, there will be an alarm set point adjustment on the front of the control. The alarm can be adjusted from 0–10% of the range of the control from the set point, in either direction. If the alarm adjustment is set to the positive side, it will act as a deviation high alarm, if it is set to the negative side, it will act as a deviation low alarm. If it is set at 0, the alarm will energize at the control set point.

WARNING:

Failure of the thermocouple-RTD sensor, heater output relay, temperature control, or other devices can result in severe damage to a product while in process, melting of the heater, or a damaging fire. An over-temperature protection device must be included in your process that will remove all power from the heater circuit if any of the above failures occur. It is recommended that this device be classified as a safety control. Failure to install such a device where a potential hazard exists could result in damage to equipment and property, and injury to personnel.

Troubleshooting

Common causes of failures:

- Line wires improperly connected
- Incorrect voltage between line terminals
- No voltage between line terminals
- Connections to terminals are loose, open, or missing
- Short across terminals
- Shorted thermocouple leads
- Thermocouple is open at tip
- Thermocouple lead is broken
- Open or shorted heater circuit
- Open coil in external contactor
- Burned out contactor
- Burned out line fuses
- Defective line switches
- Defective circuit breakers.

If the control still does not function after these points have been checked, the instrument should be returned to Tempco for inspection. Make sure to use adequate packing materials to prevent damage during shipment.

Note that no products returned can be accepted without a completed Return Material Authorization (RMA) form.

Function of Solder Gaps J1–J11

Location	Short	Open	Function
J1	x		T/C type J or K
"		x	PT100 ohms DIN or JIS
J2		x	Reverse control
"	x		Direct control
J3	x		100°C span
J4	x		200°C span
J5	x		300°C span
J6	x		400°C span
J7	x		460°C span
J8	x		600°C span
J9	x		800°C span
J10	x		1200°C span
J11	x		ON-OFF control
"		x	Time proportional control

Function of Solder Gaps J12–J13

J12	J13	Cycle time	Function
Short	Short	20 sec.	Relay output
Open	Short	1 sec.	SSR drive
Open	Open	0.02 sec.	Linear current or voltage output

Function of Solder Gaps J14–J15

J14	J15	Function
Short	Open	Positive setting
Open	Open	Positive and negative setting
Open	Short	Negative setting

Ordering Code:

TEC-805-

Power Input BOX 1

4 = 90-264 VAC 50/60 Hz

Control Mode BOX 4

1 = On - Off (used for valves and solenoids)
2 = Proportional (common for electric heaters)

Output 2 BOX 6

0 = Not Available

Signal Input BOX 2

1 = Thermocouple: Type J
2 = Thermocouple: Type K
3 = RTD: 100 ohm PT, DIN 0.00385
4 = RTD: 100 ohm PT, JIS 0.00392
9 = Other

Output 1 BOX 5

1 = Relay: 5A / 240 VAC
2 = Pulse dc for SSR drive: 20 VDC (20 mA max)
3 = 4-20 mA, linear (max load 500 ohms)
4 = 0-20 mA, linear (max load 500 ohms)
5 = 0-10 VDC, linear (min. impedance 500K ohms)
9 = Other

Alarm BOX 7

0 = None
1 = Relay: 2A / 240 VAC
Deviation alarm

Range code BOX 3

X = 0 to 499°F C = 0 to 299°C
V = 0 to 999°F E = 0 to 499°C
W = 0 to 1999°F H = 0 to 999°C
Other ranges are available for large volume orders. Consult Tempco for more information.

Communication BOX 8

0 = Not Available

RETURNS

No product returns can be accepted without a completed Return Material Authorization (RMA) form.

TECHNICAL SUPPORT

Technical questions and troubleshooting help is available from Tempco. When calling or writing please give as much background information on the application or process as possible.

TEMPCO Electric Heater Corporation

607 N. Central Avenue
Wood Dale, IL 60191-1452 USA
E-mail: techsupport@tempco.com
Phone: 630-350-2252 Toll Free: 800-323-6859
Web: Tempco.com

Note: Information in this manual was deemed correct at the time of printing. The policy of Tempco is one of continuous development and product improvement, and we reserve the right to modify specifications and designs without prior notice. Not responsible for typographical errors.

Custom Manufacturer Since 1972

ELECTRIC HEATING ELEMENTS • TEMPERATURE CONTROLS • SENSORS • PROCESS HEATING SYSTEMS

HEAT THINGS UP!

With Thousands of Design Variations
We Make Everything You Need.

Band Heaters	Cartridge Heaters
Cast-In Heaters	Coil & Cable Heaters
Radiant Heaters	Strip Heaters
Flexible Heaters	Tubular Heaters
Process Heaters	Instrumentation
Temperature Control	Temperature Sensors



607 N. Central Avenue Wood Dale, IL 60191-1452 USA
P: 630-350-2252 Toll Free: 800-323-6859
F: 630-350-0232 E: info@tempco.com
www.tempco.com